

Work happily



V1.0

naggura'swop

naggura.com

Our products



Medical Examination

S301

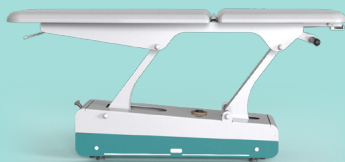

Swop 301 is an all-round electrical treatment table! Simply multipurpose!

Wood, Metal or Pmma



Collections

Nordic
METAL

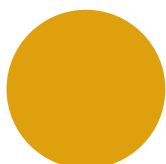

Yellow

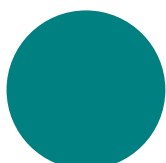

Blue

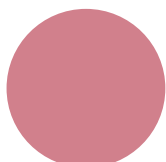

Pink

Foll
METAL

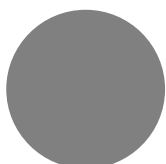

Ash

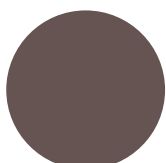

Clay

Iron
METAL

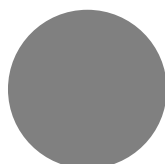

Inox

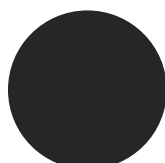

Black

Om
WOOD



Oak



Wenge

Techno
PMMA



Fluor

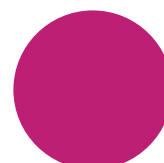

Fuxia



Ice

S301

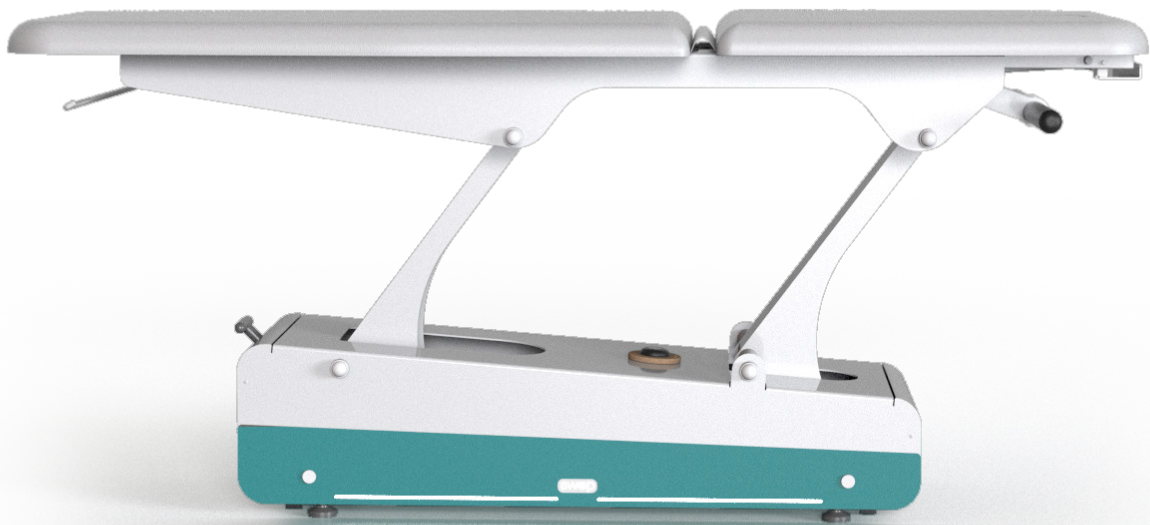

Dimensions

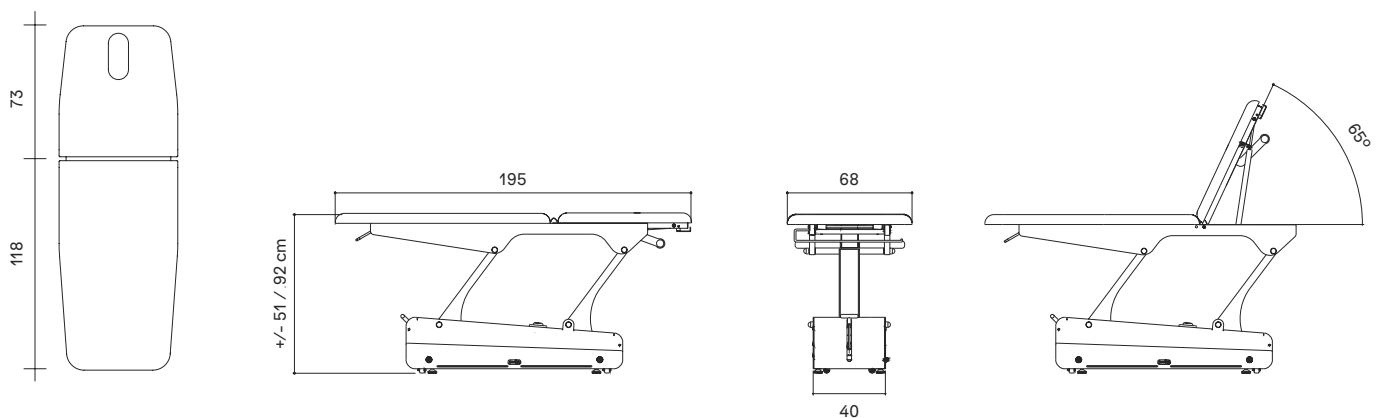

General Specifications

MOTORS

1 engine (height)

DIMENSIONS (LENGTH X WIDTH)

195 x 68 cm

HEIGHT (MIN. AND MAX.)

51/92 cm

WEIGHT

92 kg

THICKNESS

6 cm

DENSITY

30 kg/m³

LIFTING CAPACITY

175 kg

OPERATION

Hand controller (included)/
Foot controller (optional)

POWER SUPPLY

230 V - 50/60 Hz

MAX. INTENSITY

2 A

ELECTRIC MOTOR

6.000 N

CUSHION

Seamless Upholstery and
round edges.

100% Vinyl-compound

Permablok 3 advanced vinyl
protection (against germs,
abrasion), UV resistant, supe-
rior abrasion 300K Grey colour

Permaguard advanced vinyl
protection (against germs and
stains), UV resistant, abrasion
100K White colour