

AC-2000 Series Colposcope User's Manual

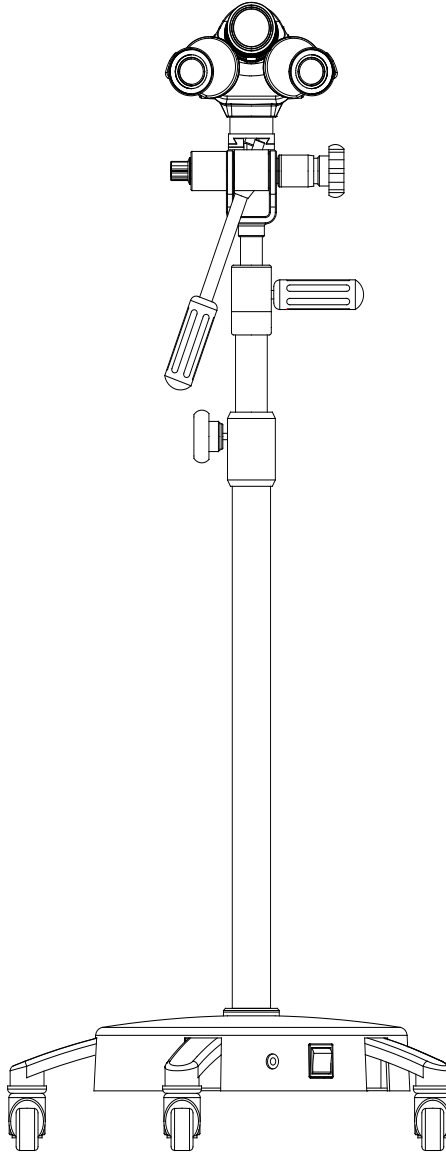

(Please read the instruction carefully before using it)



AC2000-UM02-EN

Version: B3

14/09/2020

Alltion (Guangxi) Instrument Co., Ltd.

Product Information:

Product Name: Colposcope

Product Model: AC-2000 series

Date of Manufacture: Please see the instrument label

Manufacturer:

Alltion (Guangxi) Instrument Co.,Ltd.

Manufacturing Address: No. 10, 3 Road, Industrial Park, Wuzhou, Guangxi

E-Mail: *sales@alltion.com or sales@alltion-microscope.com*



















Phone: +86-774-2836101

Fax: +86-774-2836192

Postal Code: 543000

Website: *http://www.alltion.com*

 Symbols, labels and information:

	Manufacturer		Authorized representative in the European community
	Serial number		Medical Device complies with Directive 93/42/EEC
	Date of manufacture		PSE label
	Lot number		Consult instructions for use
	WEEE disposal		Fragile, handle with care
	Keep in a cool, dry place		Upward
	For indoor use		Equipotentiality
	Product code		Temperature limitation
	Moisture limitation		Atmospheric pressure limitation



Obelis s.a

Bd. Général Wahis 53 1030 Brussels, BELGIUM



Alltion (Guangxi) Instrument Co., Ltd

Alltion Building, NO.10, 3rd Road, Wuzhou Industrial Park,

Wuzhou, Guangxi, China 543000

Made in China

Imported by:

GIMA S.p.A. - Via Marconi, 1 - 20060 Gessate (MI) - Italy

Security Warning

For using the instrument safely in a correct way and ensuring the instrument in a good state ,please read this instruction carefully before operating .

It shall change some components to improve the quality and performance of instrument. Therefore, it may has some different with the instruction. Please know that the stander equipment be provided by factory shall prevail.



Please attach importance to and perform the contraindications and announcements



In order to prevent the instrument from tipping during handling, please keep the instrument at the lowest position.

Tilting Base: Do not place the instrument on a surface that is more than 5 degrees. There is a risk of imbalance.

Contents

1	Introduction.....	1
1.1	Product Feature	1
1.2	Adaptation of Product.....	2
1.3	Product Formation.....	2
2	Security.....	2
2.1	Intended Use	2
2.2	The Environment For Use	3
2.3	Feature of Security	3
3	Instruction For Colposcope	4
3.1	Three-Step Colposcope (L Stand)	4
3.2	Three-Step Colposcope (Upright Stand)	6
3.3	Indications for Use.....	8
3.4	Features.....	8
4	Installation of Colposcope.....	8
4.1	Contents of Box.....	8
4.2	Removing the Colposcope From the Box	8
4.3	Setting Up the Colposcope.....	9
5	Adjustment of the Eyepieces	9
5.1	To Adjust the IPD (5C).....	9
6	Adjustment of the Diopter Knobs	10
7	Colposcope Instructions for Use.....	11
8	Selecting Your Preferred Level of Magnification.....	12
9	Integrated Video Camera	13
10	Storage and Precautions	13
11	Moving the Colposcope	13
12	TECHNICAL DATA CONTINUED	14
13	Troubleshooting.....	18
14	Information about disinfection for Alltion LED Colposcope	19
15	Disposal.....	Errore. Il segnalibro non è definito.
16	GIMA WARRANTY TERMS.....	19

1 Introduction

1.1 Product Feature

- Vaginal surgery microscope (Colposcope) apply to gynecological microsurgery and gynecological examination.

- The Colposcope of AC-2000 series have 2 model with one-step magnification and three-step magnification, huge depth of field, improve contrast by green filter, can acquire high definition images, excellent 3D percept, can identify microscopic variation by high quality illuminant and high magnified image; and can show the nidus on the monitor clearly(AC-2311).Doctor can observe the nidus on the monitor, operate easily, can use for diagnostics and treatment. It provide more advanced ways to clinical diagnosis and teaching research.

- Classified by prevent electric shock type: II type
- Colposcope model labeled graph as follows:

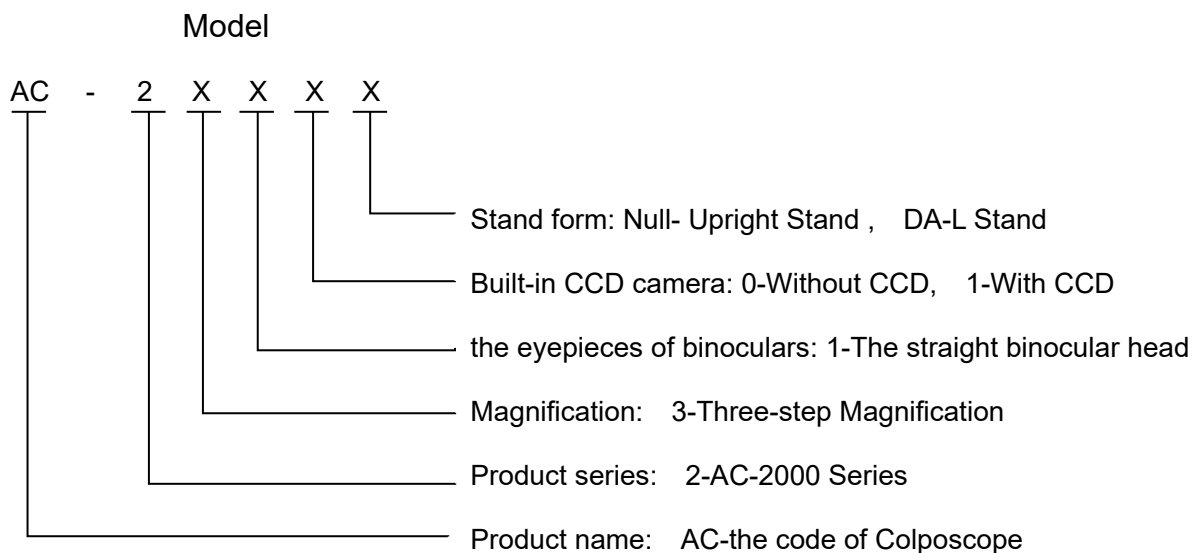

- Adoption Standard
IEC60601-1, IEC60601-1-2
- Intended Service Life: 10 years

1.2 Adaptation of Product

The Colposcope apply to clinical observation for the lesion of vagina, cervix, vulva, etc.



Contraindication:

- (1) Should not checking during menstrual period or vaginal bleeding**
- (2) Should not perform gynecological examination and cervical scraping smear before 24 hours of vaginal examination to avoid the damage of epithelial cell.**
- (3) Should not have sex 3 hours before the vaginal examination.**
- (4) Should not take bath in tub ,vaginal douche and use suppository 1 day before the vaginal examination**

1.3 Product Formation

The Colposcope of AC-2000 series are composed with optical system (include objective, variable-power lens, eyepiece, illuminating system, stand and electrical system. You can choice various corresponding mountings for different requirements, such as CCD and so on.

2 Security

2.1 Intended Use

The Colposcopy Examination can help doctor to discover and ensure the information(location, detail, condition, range and extent) of cervical erosion, cervical polyp, cervical intraepithelial neoplasia(CIN),cervical cancer, colpitis, cervicallntraepithelial neoplasia, subclinical vulvar papilloma lesion.

The Colposcope is not only worth diagnosing cervical precancerous lesions and distinguishing tumor or inflammation, but also have special applied worth in treatment, especially the lesion of cervical intraepithelial neoplasia(CIN).Because the colposcope can see the location and range of epithelia changement, you can use the colposcope take more information about the examination of urethra and vulva in the same way. Its main function:

- Ensure cervical precancerous lesions, it is in favor of wipe out earlier, prevent it grow into cancer;
- Choice abnormal lesion, Locating biopsy, Increase the positive rate of biopsy;

- Ensure the extent of disease, especially cervical canal;
- Ensure the Squamous Colum Junction(SCJ) is normal or abnormal and the range of transition zone;
- Distinguish infiltrating carcinoma.

2.2 The Environment For Use

a) Transport and Storing

- Ambient Temperature Range: $-40^{\circ}\text{C} \sim 55^{\circ}\text{C}$;
- Relative Humidity Range: $10\% \sim 80\%$;
- Barometric Pressure Range: $500 \text{ hPa} \sim 1060 \text{ hPa}$ 。

b) Operation

- Ambient Temperature Range: $5^{\circ}\text{C} \sim 40^{\circ}\text{C}$;
- Relative Humidity Range: $30\% \sim 80\%$;
- Barometric Pressure Range: $700 \text{ hPa} \sim 1060 \text{ hPa}$;
- Power Supply: DC12/3A (Adapter:Input:AC100-240V 50/60Hz, Output:DC12V 3A)。

2.3 Feature of Security

- Classified by prevent electric shock type: **II** type;
- Classified by prevent electric shock degree: **No Applied Part**;
- Classified by input fluid protection degree: **IPX0**
- The Colposcope doesn't belong to **AP&APG** equipment;
- Classified by operation mode: continuous operation;
- Power Supply: DC12/3A (Adapter:Input:AC100-240V 50/60Hz, Output:DC12V 3A)。
- Max input power: 32VA;
- The Colposcope can not defend the defibrillator discharge ;
- The colposcope have a accessory what build-in optical splitter camera with a signal output unit which is HDMI 1080P

3 Instruction For Colposcope

3.1 Three-Step Colposcope (L Stand)

Featuring LED Light Source

- * Lasts longer
- * Cool to the touch

- [1] LED Bulb cover
- [4] Head Inclination Knob
- [5] Fine Height Adjustment Handle
- [6] Fine Focus Handle
- [7] Gross Height Adjustment and Locking Knob
- [8] The Rolling Base, with 5 locking wheels
- [9] On/Off Switch and Power Indicator Light
- [10] L Stand

Rolling Base



Tilting Base

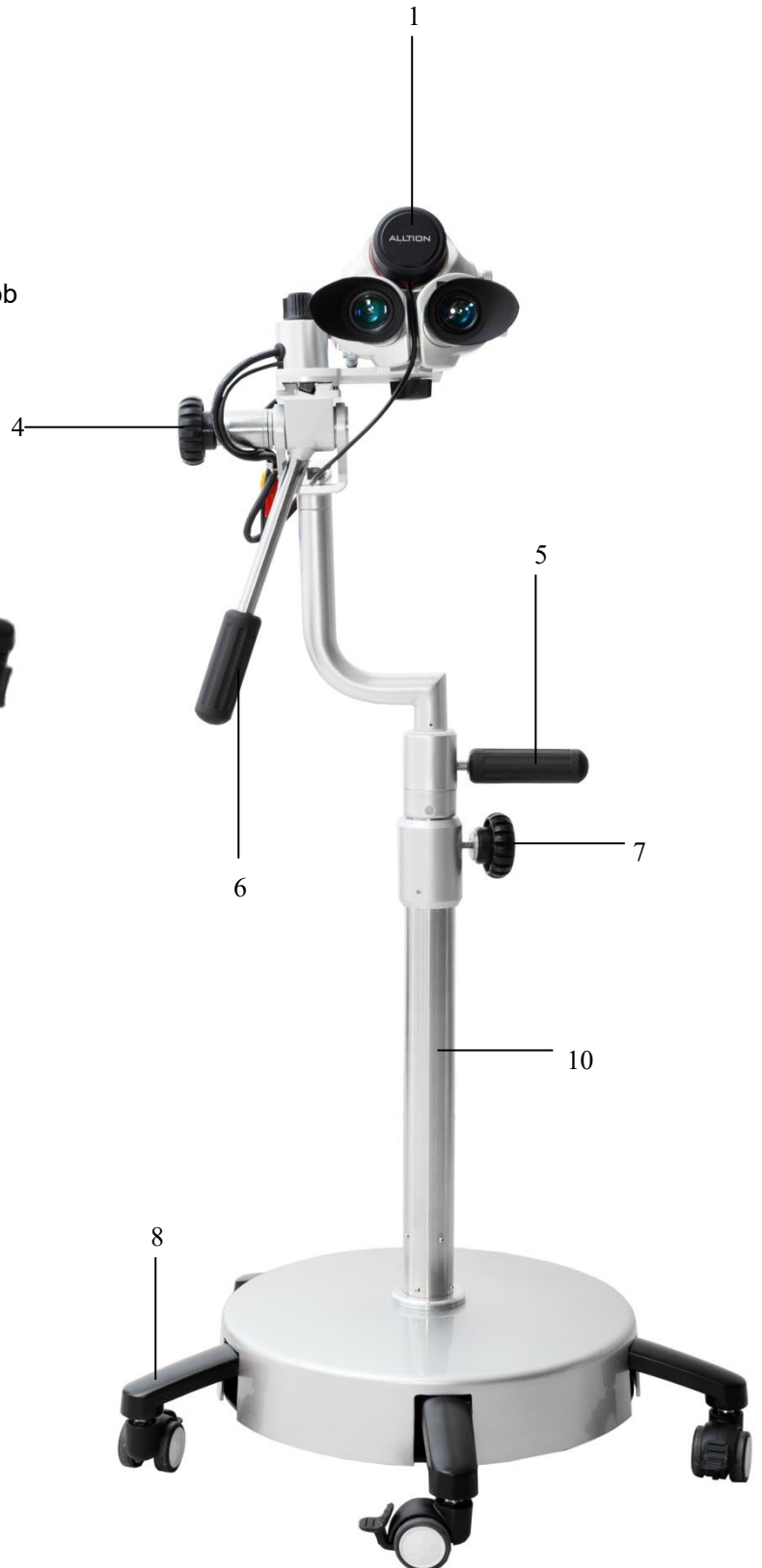
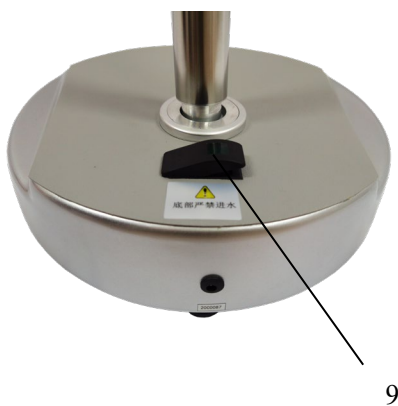

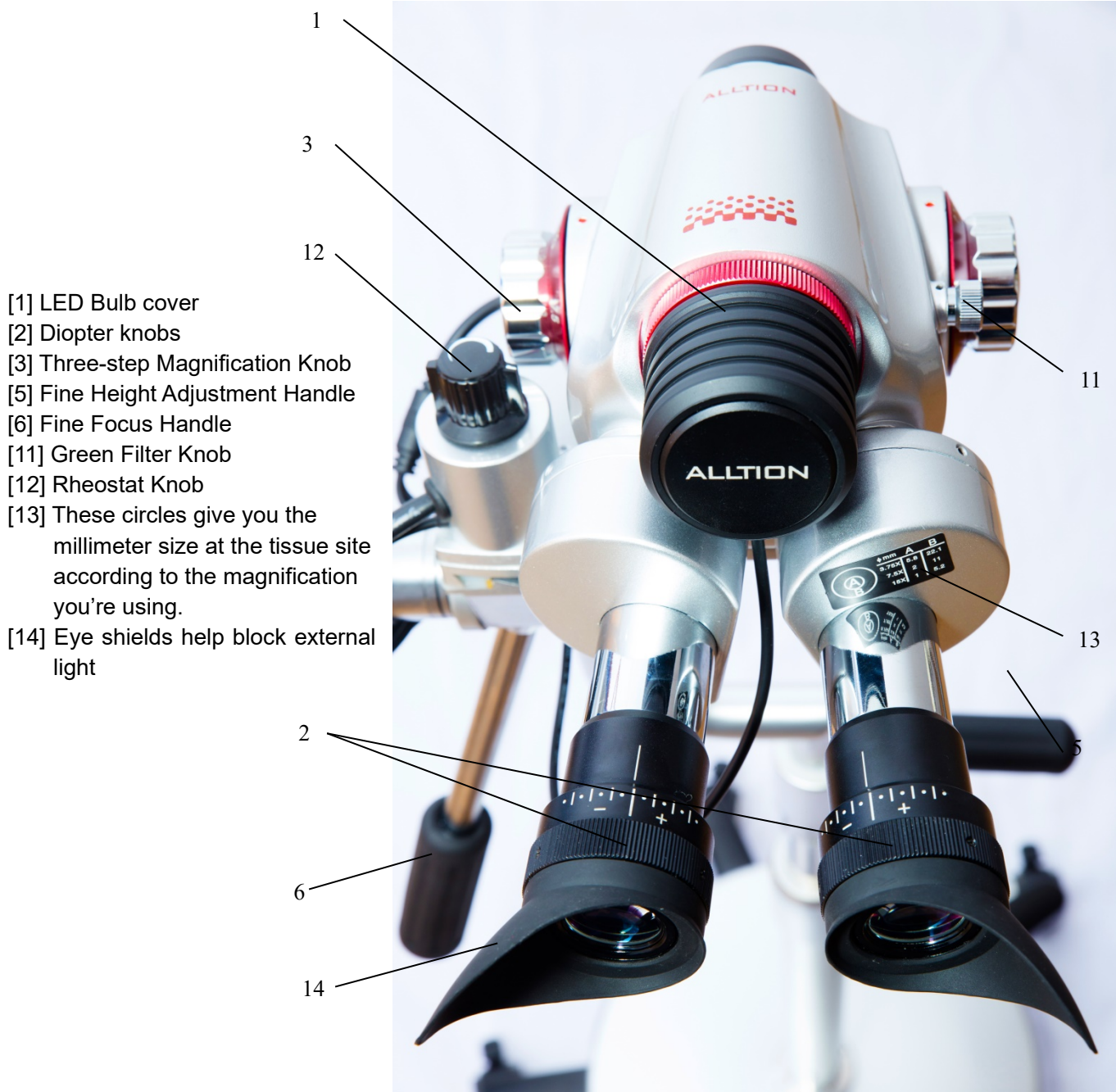

- [1] LED Bulb cover
- [2] Diopter knobs
- [3] Three-step Magnification Knob
- [5] Fine Height Adjustment Handle
- [6] Fine Focus Handle
- [11] Green Filter Knob
- [12] Rheostat Knob
- [13] These circles give you the millimeter size at the tissue site according to the magnification you're using.
- [14] Eye shields help block external light

AC-2311DA (Rolling Base) Label	AC-2311DA (Tilting Base) Label
<p>ALLTION Name: Colposcope Model: AC-2311DA Power Supply: DC12V 3A CLASS I CE Obelix s.a Bd. Général Werlt 55 1000 Brussels, BELGIUM Alltione (Guangxi) Instrument Co., Ltd Alltione Building, NO.10, 3rd Road, Wuzhou Industrial Park, Wuzhou, Guangxi, China.</p>	<p>ALLTION Name: Colposcope Model: AC-2311DA Power Supply: DC12V 3A CLASS I CE Obelix s.a Bd. Général Werlt 55 1000 Brussels, BELGIUM Alltione (Guangxi) Instrument Co., Ltd Alltione Building, NO.10, 3rd Road, Wuzhou Industrial Park, Wuzhou, Guangxi, China.</p>
	<p>Transport warning Do not place the instrument on a surface that is more than 5 degrees. There is a risk of imbalance.</p> <p>Transport position At the lowest position</p>

3.2 Three-Step Colposcope (Upright Stand)

Featuring LED Light Source

- * Lasts longer
- * Cool to the touch

- [1] LED Bulb cover
- [2] Diopter knobs
- [3] Three-step Magnification Knob
- [4] Head Inclination Knob
- [5] Fine Height Adjustment Handle
- [7] Gross Height Adjustment and Locking Knob
- [8] The Rolling Base, with 5 locking wheels
- [9] On/Off Switch and Power Indicator Light
- [10] Upright Stand
- [12] Rheostat Knob

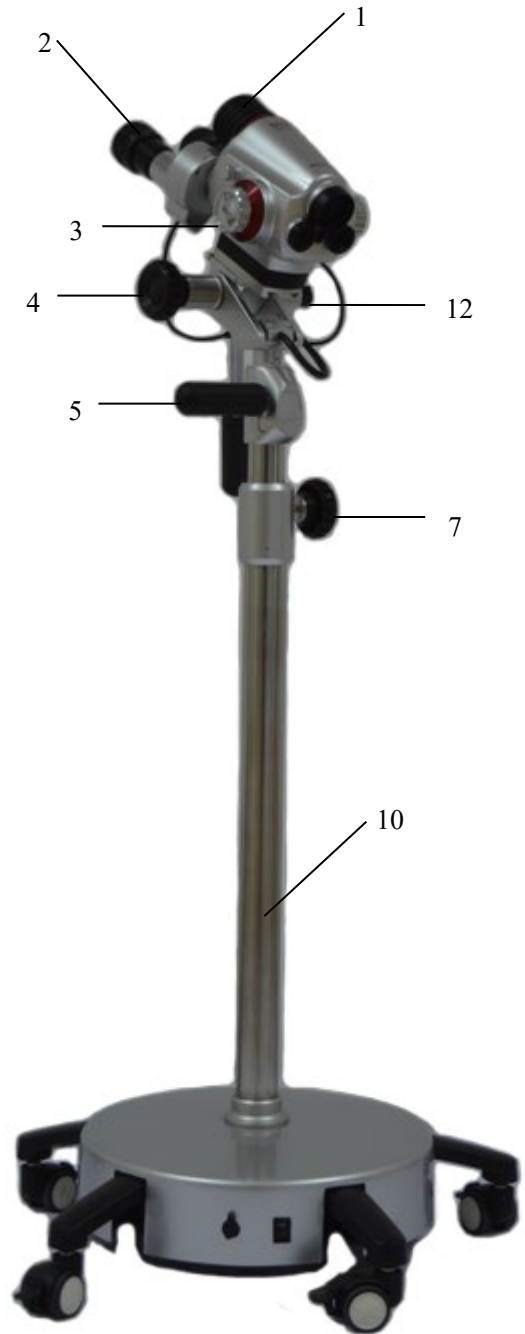
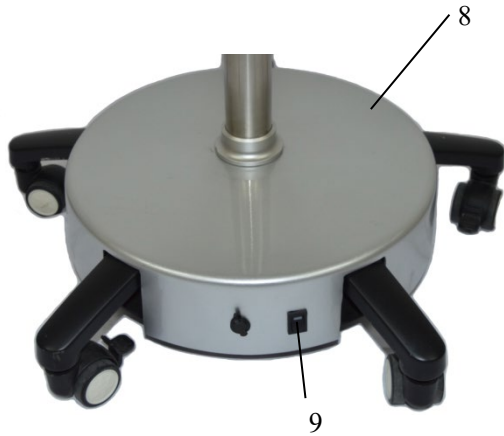

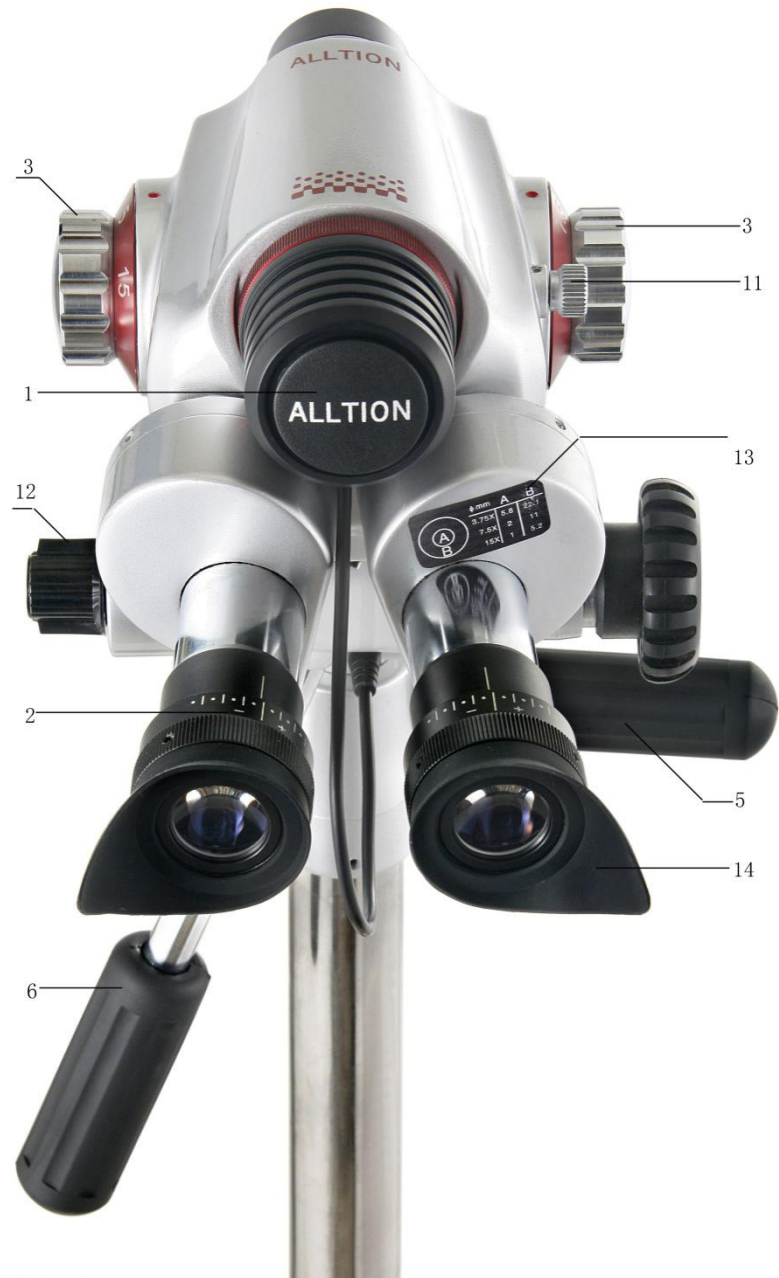

- [1] LED Bulb cover
- [2] Diopter knobs
- [3] Three-step Magnification Knob
- [5] Fine Height Adjustment Handle
- [6] Fine Focus Handle
- [11] Green Filter Knob
- [12] Rheostat Knob
- [13] These circles give you the millimeter size at the tissue site according to the magnification you're using.
- [14] Eye shields help block external light

AC-2311 (Rolling Base) Label	AC-2311 (Tilting Base) Label
<div style="border: 1px solid black; padding: 10px;"> <p style="text-align: center; font-weight: bold; font-size: 1.2em;">ALLTION</p> <p>Name: Colposcope Model: AC-2311 CE</p> <p>Power Supply: DC12V 3A CLASS I</p> <div style="display: flex; justify-content: space-between; align-items: center;"> <div style="text-align: center;"> 2011/65 2011/65 </div> <div style="text-align: center;"> EN 18C8455 </div> </div> <p style="font-size: 0.8em;">Obelisk s.a Bou. Général Walle 52 1000 Brussels, BELGIUM</p> <p style="font-size: 0.8em;">Alltion (Guangxi) Instrument Co., Ltd Alltion Building NO.10 2nd Road, Wuzhou Industrial Park, Wuzhou (Guangxi) China.</p> </div>	<div style="border: 1px solid black; padding: 10px;"> <p style="text-align: center; font-weight: bold; font-size: 1.2em;">ALLTION</p> <p>Name: Colposcope Model: AC-2311 CE</p> <p>Power Supply: DC12V 3A CLASS I</p> <div style="display: flex; justify-content: space-between; align-items: center;"> <div style="text-align: center;"> 2011/65 2011/65 </div> <div style="text-align: center;"> EN 18C8455 </div> </div> <p style="font-size: 0.8em;">Obelisk s.a Bou. Général Walle 52 1000 Brussels, BELGIUM</p> <p style="font-size: 0.8em;">Alltion (Guangxi) Instrument Co., Ltd Alltion Building NO.10 2nd Road, Wuzhou Industrial Park, Wuzhou (Guangxi) China.</p> </div> <div style="border: 1px solid black; padding: 10px; margin-top: 10px;"> <div style="display: flex; align-items: center;"> <div> <p>Transport warning</p> <p>Do not place the instrument on a surface that is more than 5 degrees. There is a risk of imbalance.</p> </div> </div> <div style="display: flex; align-items: center; margin-top: 10px;"> <div style="margin-right: 10px;"> <p>Transport position</p> </div> <div> <p>At the lowest position</p> </div> </div> </div>

3.3 Indications for Use

The ALLTION Colposcope is a device designed for viewing of the tissues of the vagina and cervix by a telescopic system located outside of the vagina. A colposcope is used to diagnose and examined abnormalities of the vagina and cervix.

3.4 Features

- * Total magnification 3.75X, 7.5X, 15X for 3-step models and 7.5X for single magnification models
- * 300mm focal length
- * Field of View: 79mm, 39mm, 19mm dia. For 3-step magnification models and 39mm for single magnification models
- * Depth of Field: 4.5mm, 1.13mm, 0.76mm for 3-step magnification models and 1.13mm for single magnification models
- * Light intensity: >25,000 LUX
- * Individually adjustable eyepiece 16.7X
- * The two built-in circles of right eyepieces can measure the size of the problem.
- * Built-in rheostat for brightness adjustment
- * User-selectable built-in green filter for enhanced contrast
- * LED bulb is easily changeable.
- * Working Height: 950mm to 1250mm (AC-2000DA: 950mm to 1150mm)
- * Fine focus adjustment Handles
- * Two(Gross/Fine)height adjustment Handles
- * Upright Stand Colposcope has been installed before leaving the factory, it can be used as long as turn on the power/ Please install the head of L Stand Colposcope before turning on the power and using it .
- * Main Power Supply: DC12/3A (Adapter:Input:AC100-240V 50/60Hz, Output:DC12V 3A)
- * CMOS Sensor: 1/2.8 in CMOS imaging sensor
- * HDMI Output Image: clear image, resolution ratio is1920x1080, the fastest speed of preview can reach 60 FPS

4 Installation of Colposcope

4.1 Contents of Box

After removing the main packing materials, you will find the colposcope components located as shown below:

- * 1 Colposcope (Upright Stand)
- * 1 Colposcope stand and 1 Colposcope head(L Stand)
- * 1 Power adaptor
- * 1 Plug (US, UK, EU, AUS)
- * 1 Plastic Dust Cover
- * 1 Instructions for use
- * 1 Cloth
- * 1 Pair Eye shields
- * 1 HDMI transmission line (only the colposcope with CCD camera have it)

4.2 Removing the Colposcope From the

Box



L Stand



Upright Stand

The Colposcope comes with a two years warranty with free repairs (Shipping not included). Please keep the box and the protective foam for at least two years in case the production need to be returned to ALLTION company for any warranty repairs. Otherwise we will charge a fee for sending a new box.

* The box must be placed in the up position according to the arrows that are printed on the outer box during being carried and unpacked.

* Remove top protective material.

* Grasp the Colposcope at the center post (A cutout in the foam for your hands is provided.) and lift the Colposcope straight out of the protective material. Note: When removing the instrument out of the protective foam, remove with care to prevent the instrument from being damaged.



Tilting Base

4.3 Setting Up the Colposcope

- A. Remove the power adapter from the shipping box.
- B. Insert the adapter into the plug located at the back end of the base(1).
- C. Insert the other end of the adapter into the wall socket.
- D. Connect the power line of stand(3) to the Camera socket(4).
- E. When the instrument need to be turned on .Press the on button(2) then the light of power indicator come up .
- F. Important: Rotate the Rheostat Knob(5) to turn on the Viewing Light. (5B.)
- G. When the instrument need to be turned off. Press the off button then the light of power indicator light of the light of power indicator go out.



5 Adjustment of the Eyepieces

You must adjust the eyepieces to your interpupillary distance (IPD).

IPD means the distance between your eyes.



5.1 To Adjust the IPD (5C)

- A. Turn on power by pressing the switch on the base.
- B. Turn the black Rheostat Knob on the left to adjust the light intensity.
Light will project from upper part of the Colposcope.
- C. Gently place your eyes against the black rubber eyepieces.
Grasp the metal housing with both hands.
Gently rotate the barrels together or apart.
- D. A singular circular image should be seen through both eyepieces.
This adjustment is similar to adjusting the eyepieces of binoculars.

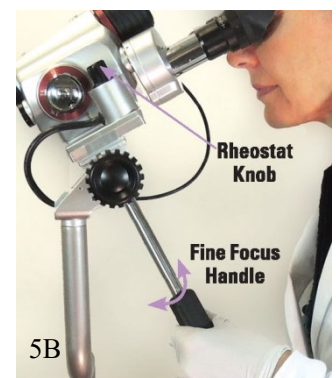

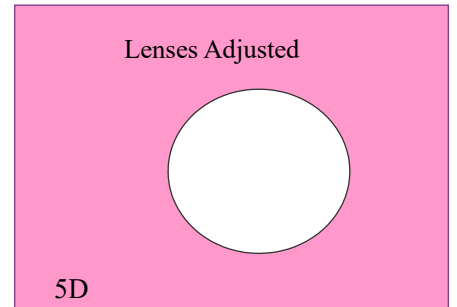
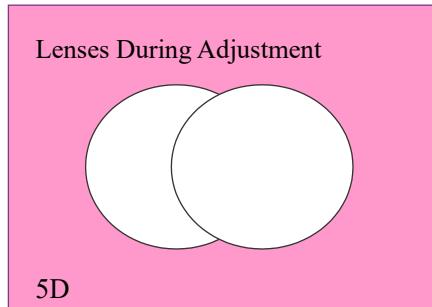
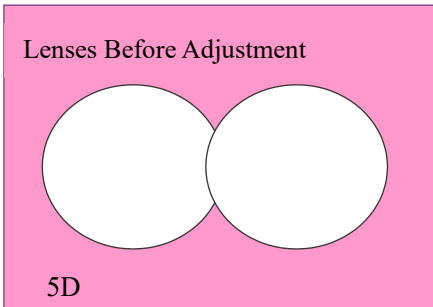
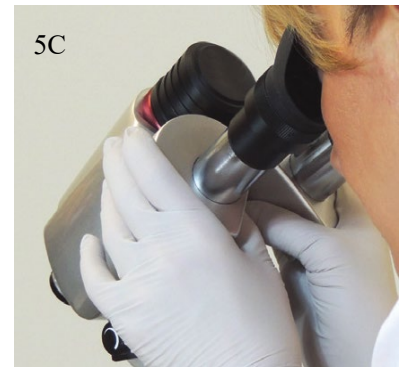
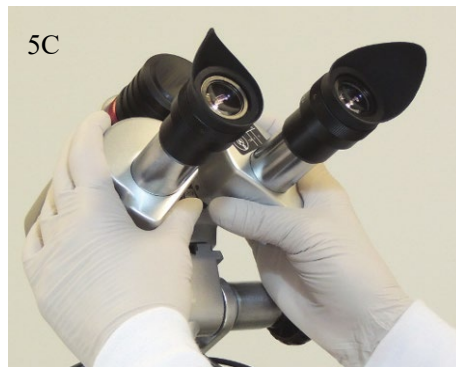
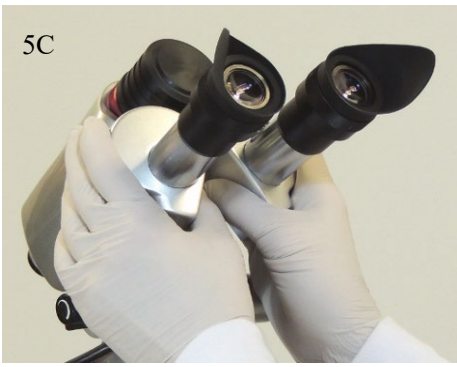

6 Adjustment of the Diopter Knobs

- Set the Diopter Knobs at zero.
- Turn the colposcope on, place your eyes against the eyepieces, and focus the colposcope on a fixed object until that object appears clear and sharp.



- It is recommended to focus on letters such as a book or a magazine. Do not focus on an object like a piece of fruit.
- Close your right eye. With your left hand, rotate the Diopter Knob until the object is clear and sharp for your left eye. Note: The Diopter allows you to adjust for plus and minus vision corrections.
- Then close your left eye. Rotate the right diopter knob with right hand until the object is clear and sharp for your right eye. Note: The Diopter allows you to adjust for plus and minus vision corrections.
- It is important to keep a record of the adjustments on the Diopters for both your left and right eyes. Since most offices have multiple people using the Colposcope, the eyepieces will be different when someone else wants to use it. By remembering your diopter settings, clarity can be achieved by simply moving the diopters to your setting when you are ready to use the Colposcope. This avoids you going through steps A–E each time.

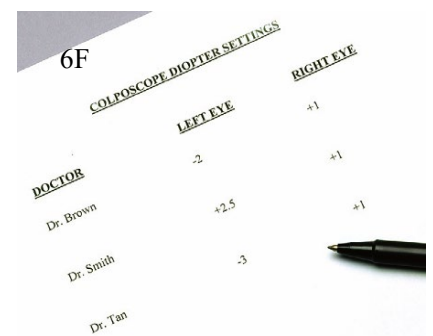

G. You will see two measuring circles through the lens. Since your Colposcope has three different magnifications, the measurement at the tissue site will vary according to the magnification you're using. The reference chart gives you the correct size per magnification change.
 Note: There is a chart on the right metal housing.

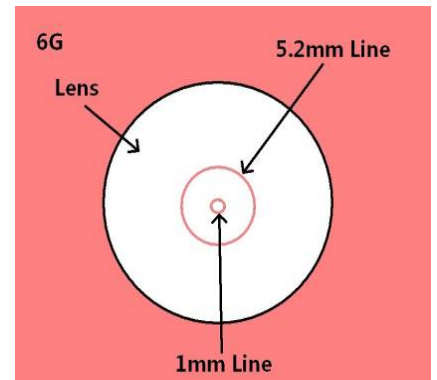
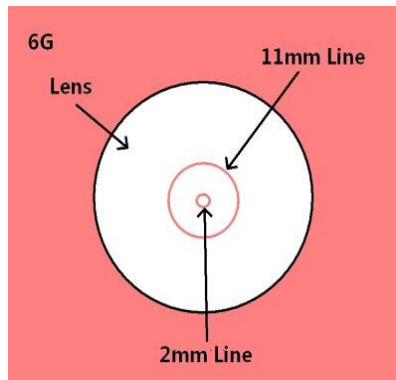
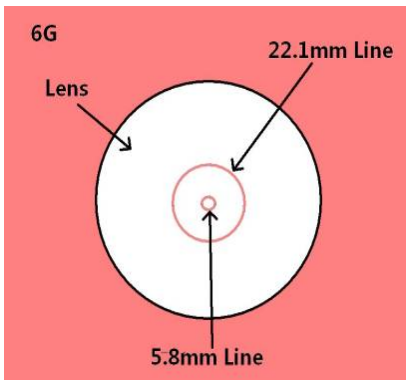

7 Colposcope Instructions for Use



The following briefly describes using the Colposcope with a patient. It is recommended that you practice using the Colposcope to familiarize yourself with all of the features it has to offer.

A. Let patient in a supine position. Your Colposcope should be placed so that the head of the scope is 300mm from the area you wish to view, with the post to as near vertical as possible. Rotate the Gross Height Adjustment and Locking Knob to loosen it and move the inner post up or down. Tighten the knob to lock the inner post in place.



B. In a sitting position, place your eyes against the eyepiece. Adjust for pupillary distance and make sure that you set your correct diopter reading. Place your right hand on the Fine Height Adjustment Handle and your left hand on the Fine Focus Handle. Note: Do not try to focus with Fine Focus.

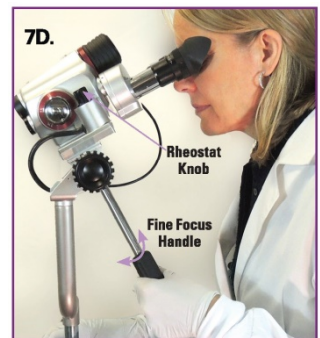

C. With your hand on the Fine Height Adjustment Handle, slowly push or pull the Colposcope, until the field comes into view.

D. Adjust the Fine Focus Controls to provide clear, magnified views of the area to be examined. Rotate your left hand on the Fine Focus Handle which will finely move the optics towards or away from the object that you wish to view. Also, rotate your right hand which is on the Fine Height Adjustment Handle up or down to raise or lower the optics. Adjust light intensity rheostat as needed by turning the black Rheostat Knob. Turn the silver Green Filter Knob for optimum assessment of affected area.

Note: Both the black Rheostat Knob and the silver Green Filter Knob are conveniently located on the

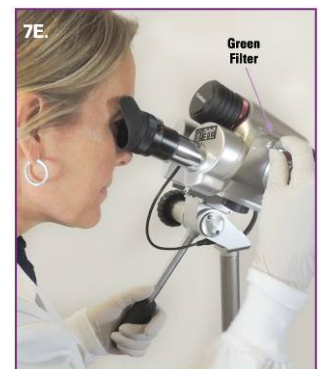

Colposcope head, thus allowing the user complete control without looking up from the eyepieces.

E. The Colposcope head may be tightened or loosened according to your preference by turning the Head Inclination Adjusting Knob.

Note on all photos

All 1 step colposcopes use the same adjustment techniques as shown on these pages, although models shown may differ.

8 Selecting Your Preferred Level of Magnification

The ALLTION offers you the advantage of increasing or decreasing magnification during a colposcopic examination.

- A. When viewing the cervix, reach up and rotate the Three-Step Magnification Knob.
- B. Rotate it to your desired magnification(3.75, 7.5, or 15).When moving from one magnification to another, slight adjustments in the fine focusing mechanism might be necessary.
- C. Turn the Fine Focus Handle.

If patient is not centered, you can move the Colposcope head in multiple directions to change your field of vision. See photos D–F.

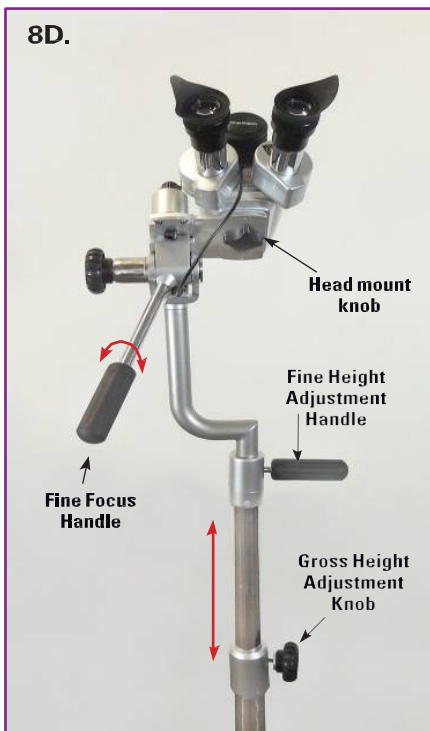

8D. Twist the Fine Height Adjustment Handle to move the head up or down slightly. Use the Gross Height Adjustment Knob to make larger height adjustments.



8E. Pull the Fine Height Adjustment Handle backward and to the right, or Push the Fine Height Adjustment Handle forward and to the left.



8F. Push the Fine Focus Handle down and forward, or pull it up and backward.

9 Integrated Video Camera

An integrated video camera (1 CCD) is available in specific models.

It is very convenient for the doctors to communicate with the patient by this device.

1.CCD camera power: connect the black wire(3) from the bracket to the camera socket in the head.

2.Video Output: Connect the attached HDMI line to the HDMI port (1) in the head, and then connect the other end of attached HDMI line to the HDMI port of TV or Monitor AV adapter.

3. Internal CCD Camera: The images from integrated video camera can be inputted into a monitor or a TV set directly. Or it can be inputted into a computer by image collection with USB 3.0 HDMI adapter or stored into a hard disk recorder



10 Storage and Precautions

A. For storage, the instrument should be placed in a clean, dry environment with stable temperatures to extend the life of the components and ensure longevity of the instrument.

B. Please cover the Colposcope with the plastic dust cover that is included with this instrument. This will keep the optics and components relatively dust free.

C. When storing or carrying the instrument, adjust the instrument to the lowest position. This will help ensure that if it is inadvertently hit, it will resist tipping over.



11 Moving the Colposcope

* Rotate the Gross Height Adjustment and Locking Knob to move the post to a comfortable position.

*Tighten the Gross Height Adjustment and Locking Knob.

*Place your foot between the wheels at the front end of the base.

*With your hand on the Fine Height Adjustment Handle, pull forward and roll across the floor.



12 Technical Data Continued

12.1 Guidance and Manufacturer's Declaration – electromagnetic Emission – for all Equipment and Systems

1	Guidance and manufacturer's declaration – electromagnetic emission		
2	The AC-2000 is intended for use in the electromagnetic environment specified below. The customer or the user of the AC-2000 should assure that it is used in such an environment.		
3	Emissions test	Compliance	Electromagnetic environment - guidance
4	RF emissions CISPR11	Group 1	The AC-2000 uses RF energy only for its internal function. Therefore, its RF emissions are very low and are not likely to cause any interference in nearby electronic equipment.
5	RF emissions CISPR11	Class A	The AC-2000 is suitable for use in all establishments, including domestic establishments and those directly connected to the public low-voltage power supply network that supplies buildings used for domestic purposes.
6	Harmonic emissions IEC 61000-3-2	Class A	
7	Voltage fluctuations / flicker emissions IEC 61000-3-3	Complies	

12.2 Guidance and Manufacturer's Declaration – electromagnetic Immunity – for all Equipment and Systems

Guidance and manufacturer's declaration – electromagnetic immunity			
The AC-2000 is intended for use in the electromagnetic environment specified below. The customer or the user of the AC-2000 should assure that it is used in such an environment.			
Immunity test	IEC 60601 test level	Compliance level	Electromagnetic environment - guidance
Electrostatic discharge (ESD) IEC 61000-4-2	± 8 kV contact ± 15 kV air	± 8 kV contact ± 15 kV air	Floors should be wood, concrete or ceramic tile. If floors are covered with synthetic material, the relative humidity should be at least 30 %.
Electrostatic transient / burst IEC 61000-4-4	± 2 kV for power supply lines	± 2 kV for power supply lines	Mains power quality should be that of a typical commercial or hospital environment.
Surge IEC 61000-4-5	± 1 kV differential mode	± 1 kV differential mode	Mains power quality should be that of a typical commercial or hospital environment.
Voltage dips, short interruptions and voltage variations on power supply input lines IEC 61000-4-11	0 % U_T ; 0.5 cycle At 0°, 45°, 90°, 135°, 180°, 225°, 270° and 315° 0 % U_T ; 1 cycle and	0 % U_T ; 0.5 cycle At 0°, 45°, 90°, 135°, 180°, 225°, 270° and 315° 0 % U_T ; 1 cycle and	Mains power quality should be that of a typical commercial or hospital environment. If the user of the AC-2000 requires continued operation during power mains interruptions, it is recommended that the AC-2000 be powered from an uninterruptible power

	70 % U _T ; 25/30 cycles Single phase: at 0° 0 % U _T ; 250/300 cycle	70 % U _T ; 25/30 cycles Single phase: at 0° 0 % U _T ; 250/300 cycle	supply or a battery.
Power frequency (50/60 Hz) magnetic field IEC 61000-4-8	3 A/m	3 A/m	Power frequency magnetic fields should be at levels characteristic of a typical location in a typical commercial or hospital environment.
NOTE U _T is the a. c. mains voltage prior to application of the test level.			

12.3 Guidance and Manufacturer's Declaration – electromagnetic Immunity – for Equipment and Systems that are not Life-supporting

Guidance and manufacturer's declaration – electromagnetic immunity			
The AC-2000 is intended for use in the electromagnetic environment specified below. The customer or the user of the AC-2000 should assure that it is used in such an environment.			
Immunity test	IEC 60601 test level	Compliance level	Electromagnetic environment - guidance
Conducted RF IEC 61000-4-6	3 V rms 150 kHz to 80 MHz 6 V in ISM bands between 0,15 MHz and 80 MHz	3 V rms 150 kHz to 80 MHz 6 V in ISM bands between 0,15 MHz and 80 MHz	Portable and mobile RF communications equipment should be used no closer to any part of the AC-2000, including cables, than the recommended separation distance calculated from the equation applicable to the frequency of the transmitter. Recommended separation distance $d = \left[\frac{3.5}{V_1} \right] \sqrt{P}$ $d = \left[\frac{3.5}{E_1} \right] \sqrt{P} \quad 80 \text{ MHz to } 800 \text{ MHz}$ $d = \left[\frac{7}{E_1} \right] \sqrt{P} \quad 800 \text{ MHz to } 2.7 \text{ GHz}$
Radiated RF IEC 61000-4-3	3 V/m 80 MHz to 2.7 GHz	3 V/m 80 MHz to 2.7 GHz	where p is the maximum output power rating of the transmitter in watts (W) according to the transmitter manufacturer and d is the recommended separation distance in metres (m). ^b Field strengths from fixed RF transmitters, as determined by an electromagnetic site survey, ^a should be less than the compliance

			<p>level in each frequency range.</p> <p>Interference may occur in the vicinity of equipment marked with the following symbol:</p> 
--	--	--	---

NOTE 1 At 80 MHz and 800 MHz, the higher frequency range applies.

NOTE 2 These guidelines may not apply in all situations. Electromagnetic is affected by absorption and reflection from structures, objects and people.

^a Field strengths from fixed transmitters, such as base stations for radio (cellular/cordless) telephones and land mobile radios, amateur radio, AM and FM radio broadcast and TV broadcast cannot be predicted theoretically with accuracy. To assess the electromagnetic environment due to fixed RF transmitters, an electromagnetic site survey should be considered. If the measured field strength in the location in which the AC-2000 is used exceeds the applicable RF compliance level above, The AC-2000 should be observed to verify normal operation. If abnormal performance is observed, additional measures may be necessary, such as reorienting or relocating the AC-2000.

^b Over the frequency range 150 kHz to 80 MHz, field strengths should be less than 3V/m.

12.4 Recommended Separation Distances between Portable and Mobile RF Communications Equipment and the Equipment or System-for Equipment and Systems that are not Life-Supporting

Recommended separation distances between portable and mobile RF communications equipment and the AC-2000

The AC-2000 is intended for use in an electromagnetic environment in which radiated RF disturbances are controlled. The customer or the user of the AC-2000 can help prevent electromagnetic interference by maintaining a minimum distance between portable and mobile RF communications equipment (transmitters) and the AC-2000 as recommended below, according to the maximum output power of the communications equipment

Rated maximum output of transmitter W	Separation distance according to frequency of transmitter		
	150 kHz to 80 MHz $d = \left[\frac{3.5}{V_1}\right]\sqrt{P}$	80 MHz to 800 MHz $d = \left[\frac{3.5}{E_1}\right]\sqrt{P}$	800 MHz to 2.7 GHz $d = \left[\frac{7}{E_1}\right]\sqrt{P}$
0.01	0.12	0.12	0.23
0.1	0.38	0.38	0.73
1	1.2	1.2	2.3
10	3.8	3.8	7.3
100	12	12	23

For transmitters rated at a maximum output power not listed above the recommended separation distance d in metres (m) can be estimated using the equation applicable to the frequency of the transmitter, where P is the maximum output power rating of the transmitter in watts (W) according to the transmitter manufacturer.

NOTE 1 At 80 MHz and 800 MHz, the separation distance for the higher frequency range applies.

NOTE 2 These guidelines may not apply in all situations. Electromagnetic propagation is affected by absorption and reflection from structures, objects and people.

13 Troubleshooting

Trouble	Check	Possible reason	Remedy
Illumination failure	Power switch indicator Not light	Main power broken-down	Contact a local electrician
		Never switch on the power switch.	Switch on the power switch.
		The adaptor has been melted	Replacing the adaptor
	Power switch indicator light	Illuminate brightness adjusting button is in low position	Adjust the button to the high position
		The LED has burnt.	Contact the After-sales service Dept.
	LED1 and LED2 on the circuit board is light (blue)	The LED has burnt or connection line loosening	Contact the After-sales service Dept.
LED1 and LED2 on the circuit board is light(blue) Use the diode gear of the multimeter to touch the positive and negative of the LED supply line.	LED light shiny: circuit board damage The LED not light: the circuit board and the LED are damaged	Contact the After-sales service Dept.	
Dimming fault	Adjust the dimming knob, the brightness of the LED is constant, or the brightness of the LED varies only in a darker range	Dimming potentiometer damage or connection line loosening	Contact the After-sales service Dept.
	Observe the LED3 on the circuit board: light shiny(green)	Dimming potentiometer damage or connection line loosening	Contact the After-sales service Dept.
	Observe the LED3 on the circuit board: not light	the circuit board is damaged	Contact the After-sales service Dept.
Colposcope Head Keeps Turning		The damping is not adjusted well or unlocked	Tighten Gross Height Adjustment and locking Knob

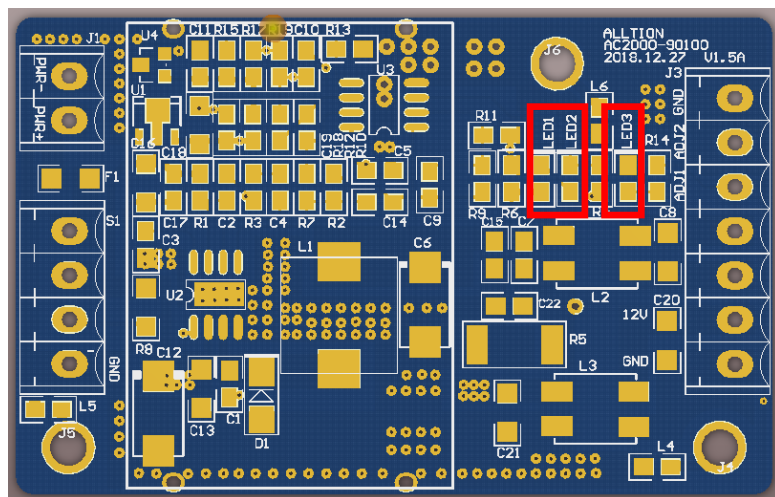

14 Information about disinfection for Alltion LED Colposcope

The cleaning of the surface of Colposcope

You can wipe the colposcope with 75% medicinal alcohol on a clean cloth, and you can use the disposable alcohol pads, usually used to clean skin. Care must be taken not to put the alcohol on any lenses, whether that be the lenses the doctor looks through or the lenses towards the patient. Should not use corrosive or scrub cleanser to clean the Colposcope

The cleaning of the surface of Optical Lens

The bloodstain or other dirt on the lens can be cleaned with lens paper or cotton wool that's with distilled water and a little of household detergent. The remaining trace can be cleaned with lens paper or cotton wool that's with 95% alcohol (wipe from centre to outside by spiral slightly). The dust on the lens can be cleaned with blown ballon or whisk pen. Should not use corrosive or scrub cleanser to clean the lens.

The sterilize for the Colposcope

All disinfectant cover can sterilize by pressure sterilizing cooker. Recommend temperature and time as follow:

- (1) Disinfect it for 10 min when the temperature is 120°C
- (2) Disinfect it for 5 min when the temperature is 134°C

 Attention: The dirt on the lens of Colposcope should be cleaned as soon as possible after using the colposcope. Otherwise it will be more difficult to clean when the dirt become hard and dry. You'd better clean and disinfect the colposcope frequently.



15 Disposal

The product must not be disposed of along with other domestic waste. The users must dispose of this equipment by bringing it to a specific recycling point for electric and electronic equipment.

16 GIMA WARRANTY TERMS

The Gima 12-month standard B2B warranty applies.